

# HOME Reformer

Now it's Pilates

Instruction manual



# 01 Precautions

1. In order to prevent customer safety accidents, please confirm the tightness of the screws before using the product.
2. Excessive use by unskilled persons is prohibited.
3. Please be careful not to pinch your fingers when unfolding or folding the product.
4. Please do a simple stretch before using the product.
5. Fix the fixing clips of the legs before use.
6. Please be careful not to pinch your hands when adjusting the strength of the springs.
7. The protector should be careful not to let children ride on the top to play.
8. This product should be installed on the floor, not near the machine with water vapor, dirt and heat.
9. We will not be responsible for any accidents that occur after use for other purposes other than the manual or the method of use uploaded on YouTube.

# 02 Size

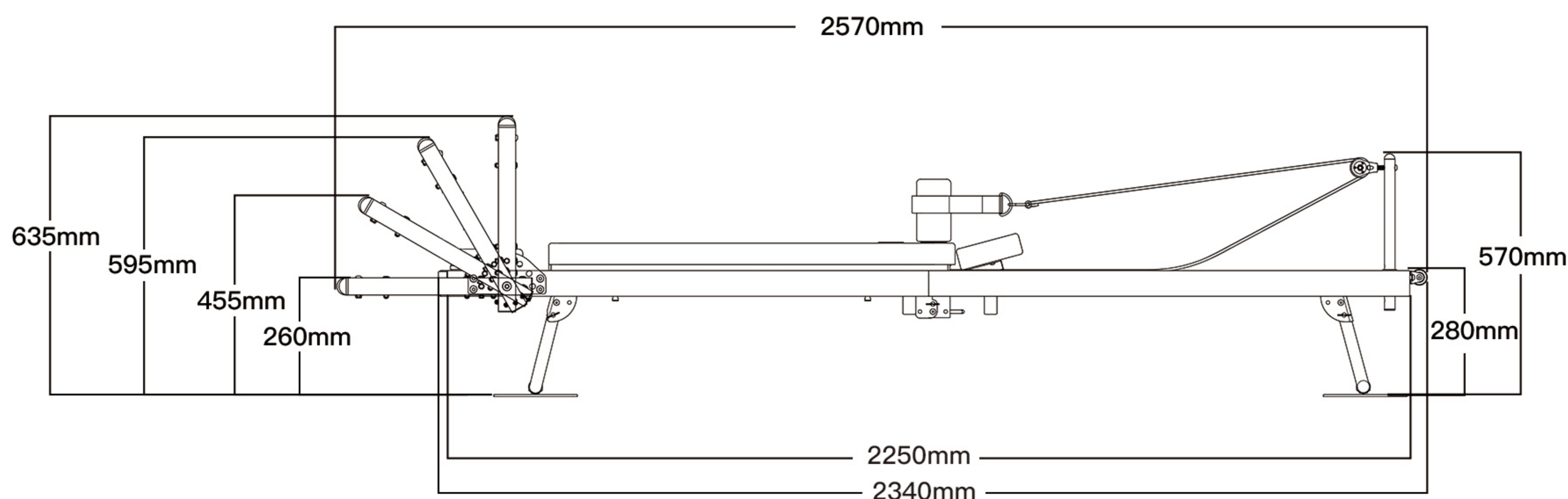

# 03 Product Composition



## Accessory Pack 1:



Stop block x2



Wheel x2

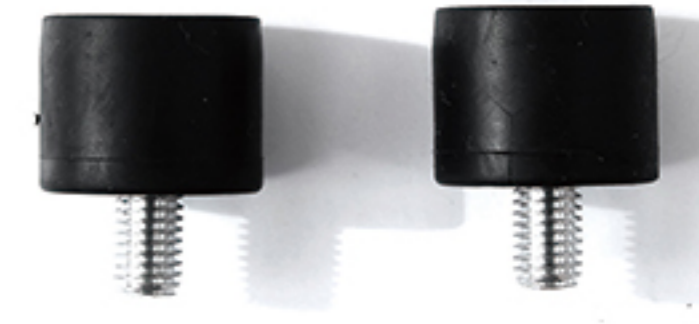

Foot pillar x2



M8\*30 Bolt x2



M8\*16 Bolt & Gasket x2



Small hex wrench x1

## Accessory Pack 2:



M10\*40 Bolt & Gasket x2



Spacer sleeve x2



Open end wrench x1



Large hex wrench x1

## Other accessories:



Armrest board x2



Hand rail rod x1



Shoulder roll x2



Headrest x1



Foot pad x2

## 04 Product manual

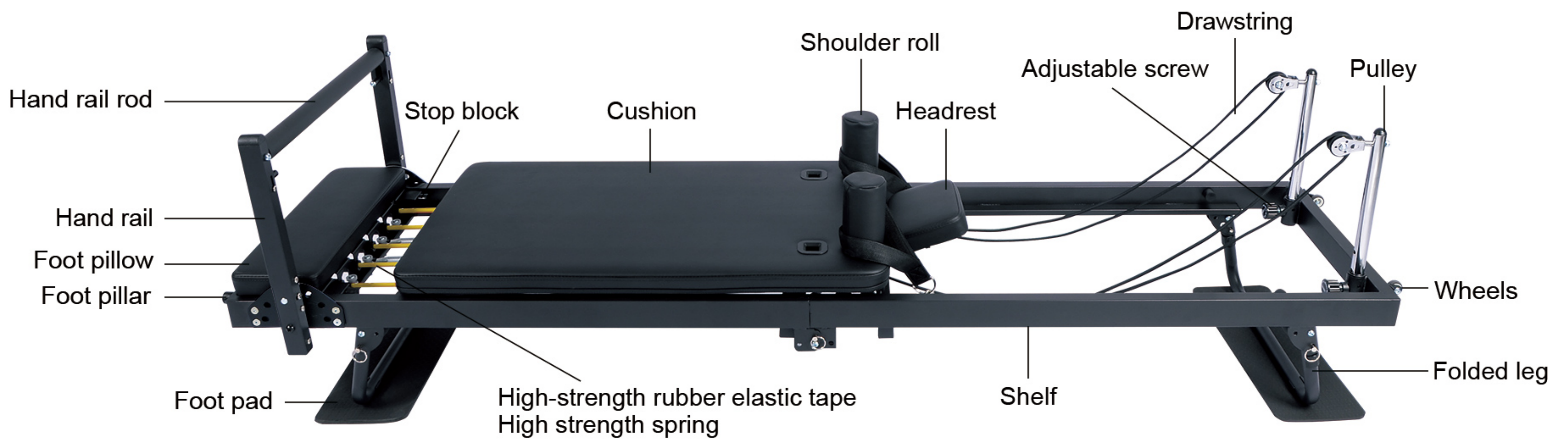

## 05 Assembly method

### Precautions when assembling

\* Please be careful not to pinch or press your hands when folding.

\* Because of the risk of injury, be sure to operate with two people when moving or assembling the product.

\* When clamping the safety clip, please lift your legs slightly, the clip will easily enter after shaking it from side to side.

1. Now clamp the fixing clip at the fixed foot. 2. Clamp at the end of the reverse side.

\* When it is difficult to change the angle, you can slightly loosen the screws connecting the two fixed feet and readjust it.

# Installation steps 01



1. Open the packaging, cut the zip ties with scissors, and remove the accessories.



2. Check the quantity of accessories.



3. Install the headrest and tighten the knob.

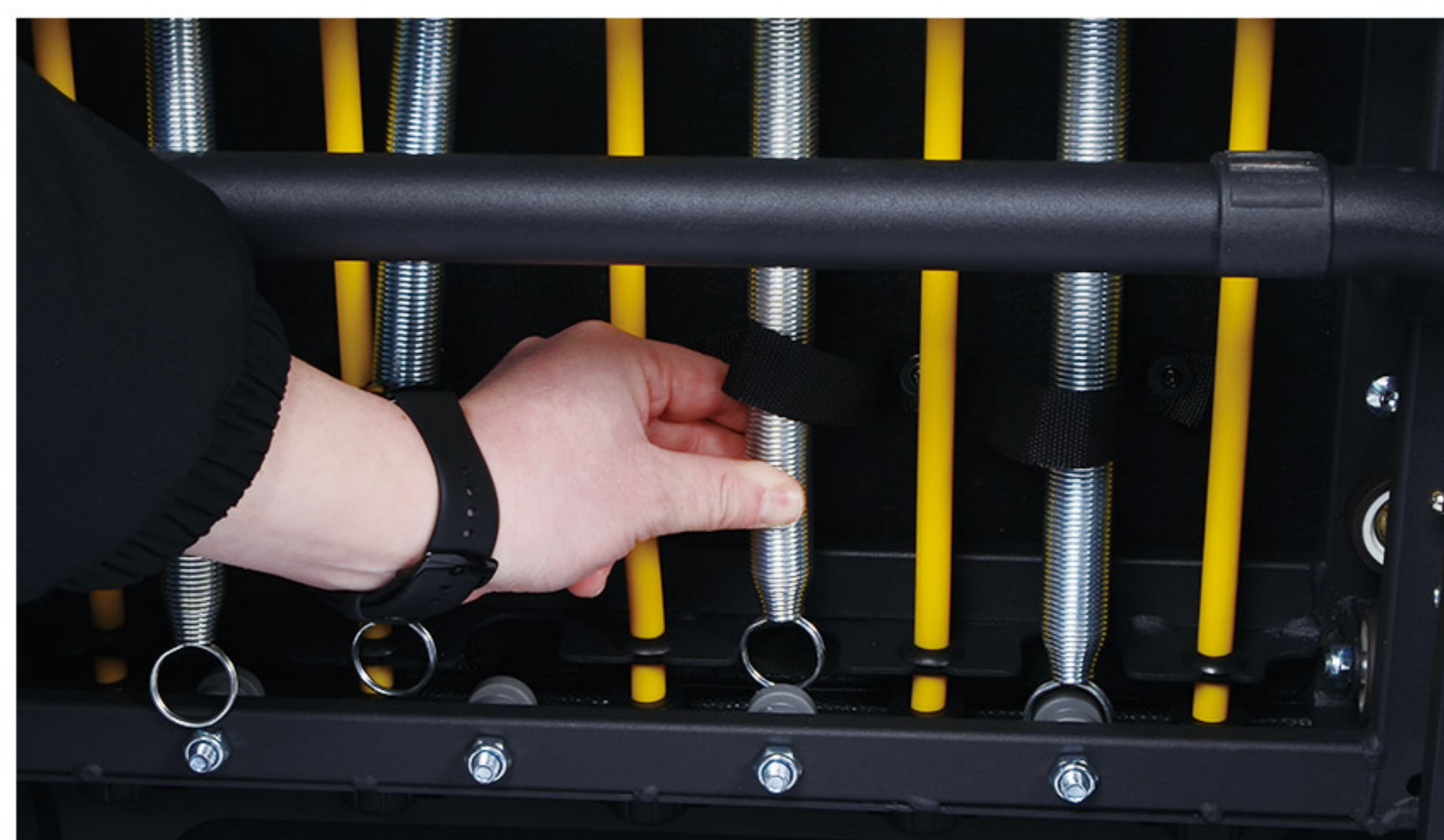

4. Remove the spring from the buckle.



5. Pull out the folding pins on both sides of the top fold.



6. As shown in the picture, lift the folding armrest and unfold the frame. (Note that two people can also collaborate to develop the framework)

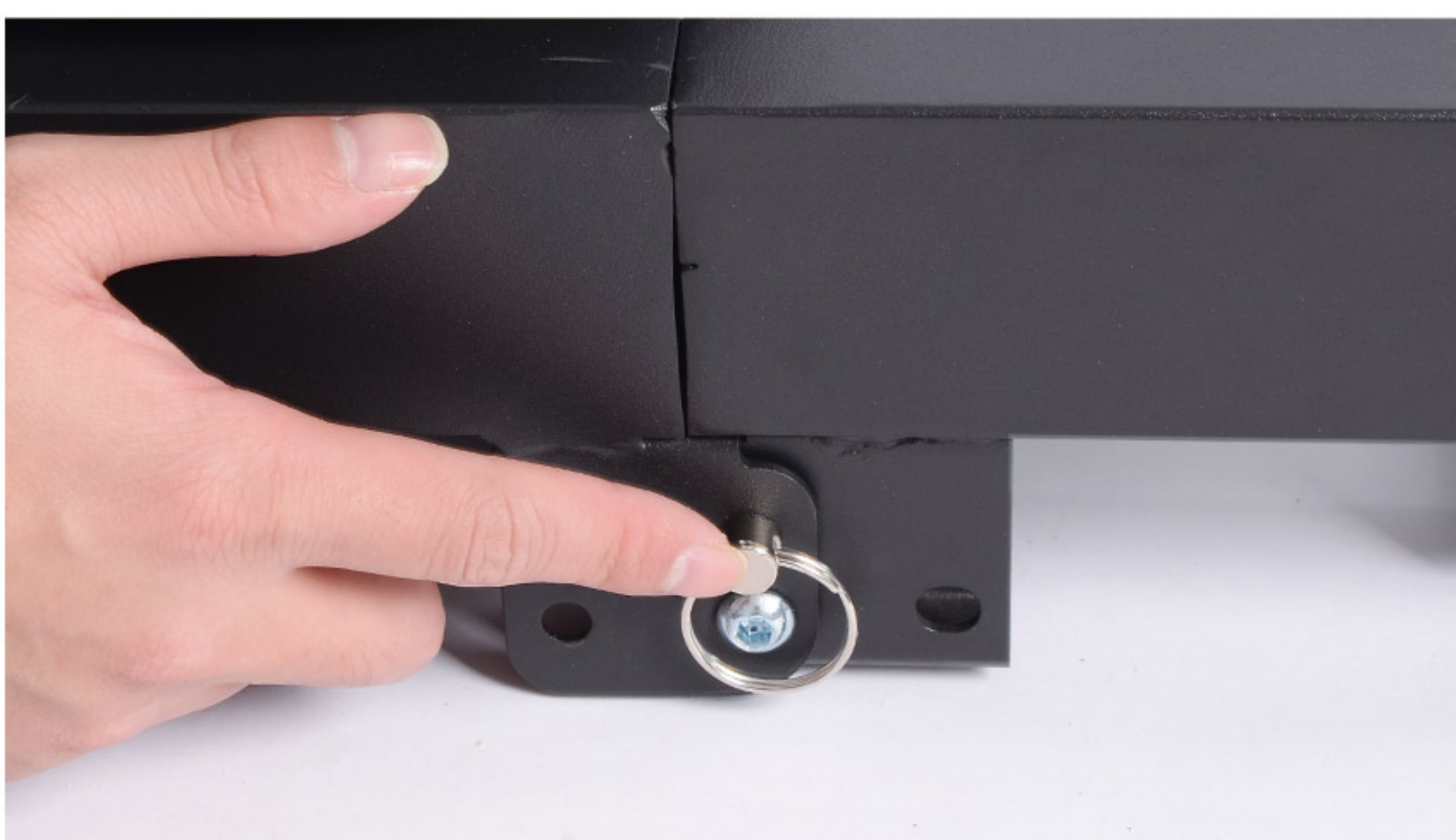

7. Insert the two folding pins into the middle hole to lock the frame.



8. Take the pulley rod and unscrew the adjustable device knob to pull it out outward.

## Installation steps 02



9. Insert the pulley rod and release the adjustable screw to lock the gear.



10. As shown in Figures 8 and 9, install the pulley rod on the other side.



11. Pull out the support pins on both sides of the rear tripod.



12. Pull out the two support pins of the front tripod.



13. Lift the frame and unfold the front stand, ensuring that the front stand is fully unfolded.



14. Insert the two support pins into the front tripod holes and lock them.



15. Unfold the rear tripod, insert the two support pins into the holes of the rear tripod and lock them.



16. As shown in the figure, insert the M10\*40 bolt into the spacer and insert it into the armrest plate hole, and install a gasket on the other side.

## Installation steps 03



17. Use a large hex wrench to tighten the bolt.



18. Unscrew the bolts and nuts from the top holes of the armrest panel.



19. Insert the handrail into the hole of the handrail board.

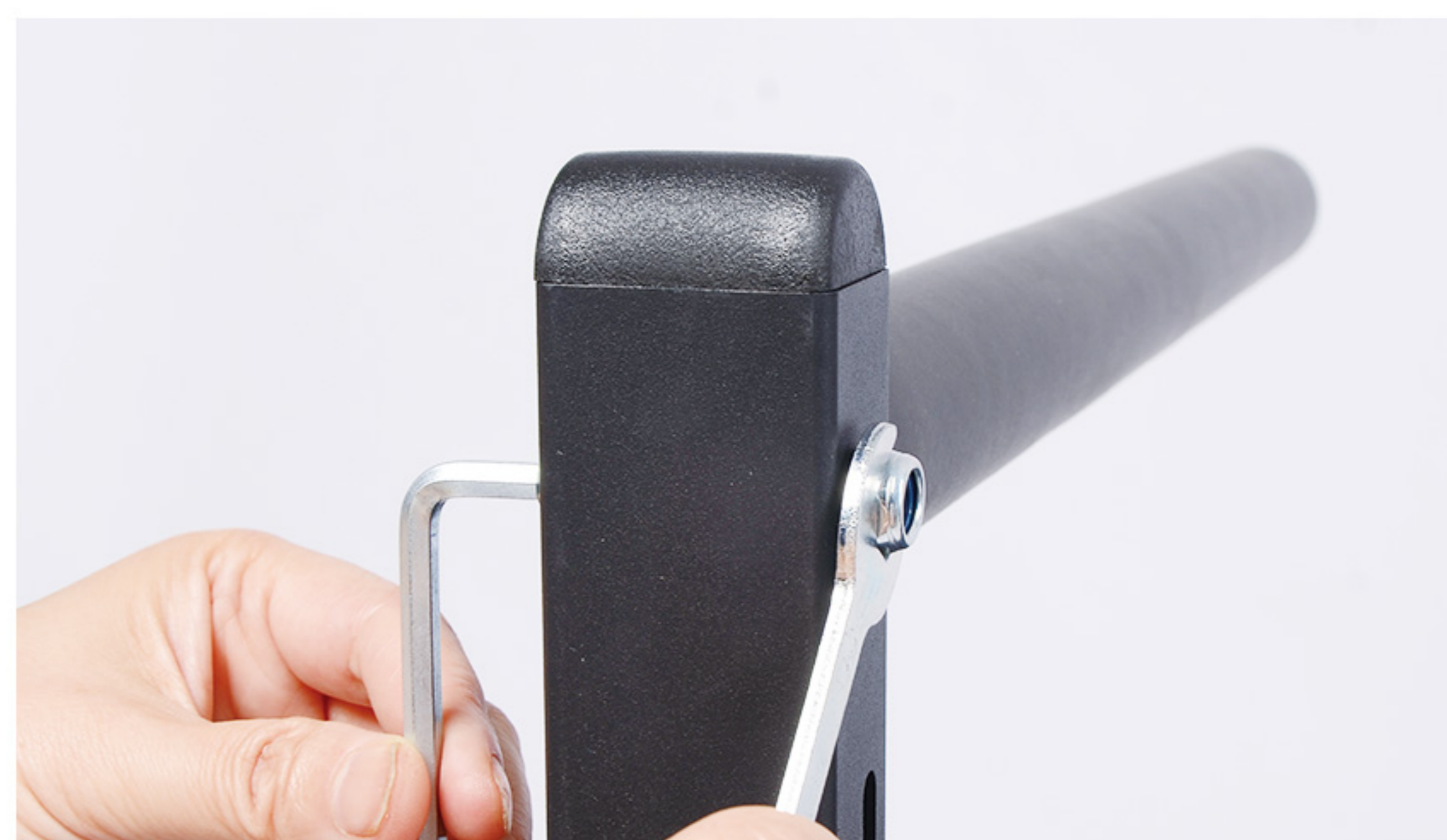

20. Insert the bolt into the hole and tighten the nut with a small hex wrench and an open-end wrench.

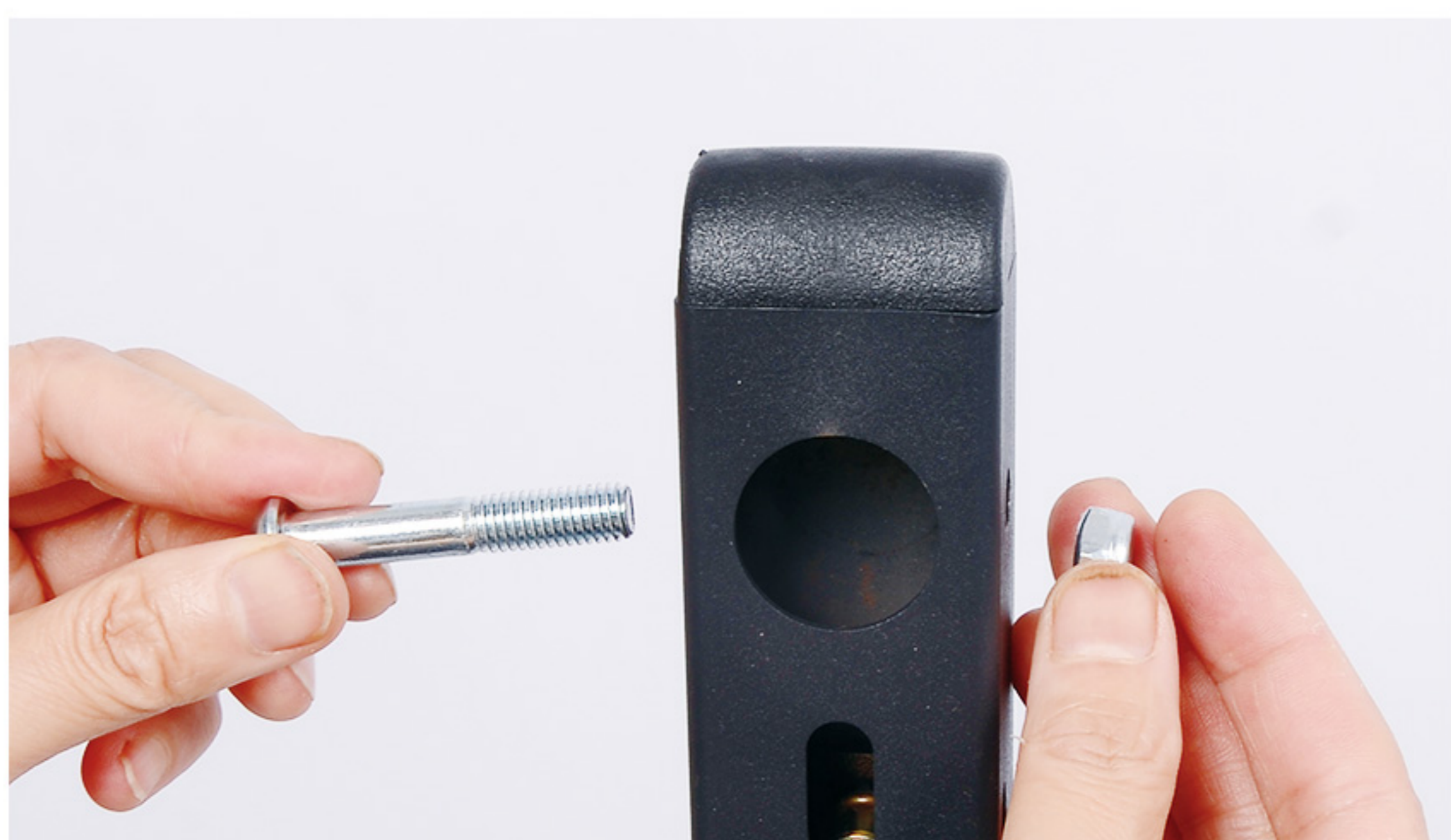

21. Take another armrest and unscrew the bolts and nuts in the top hole.



22. Insert the armrest rod into the plate hole, install the bolt, and use a small hex wrench and an open-end wrench to tighten the nut.

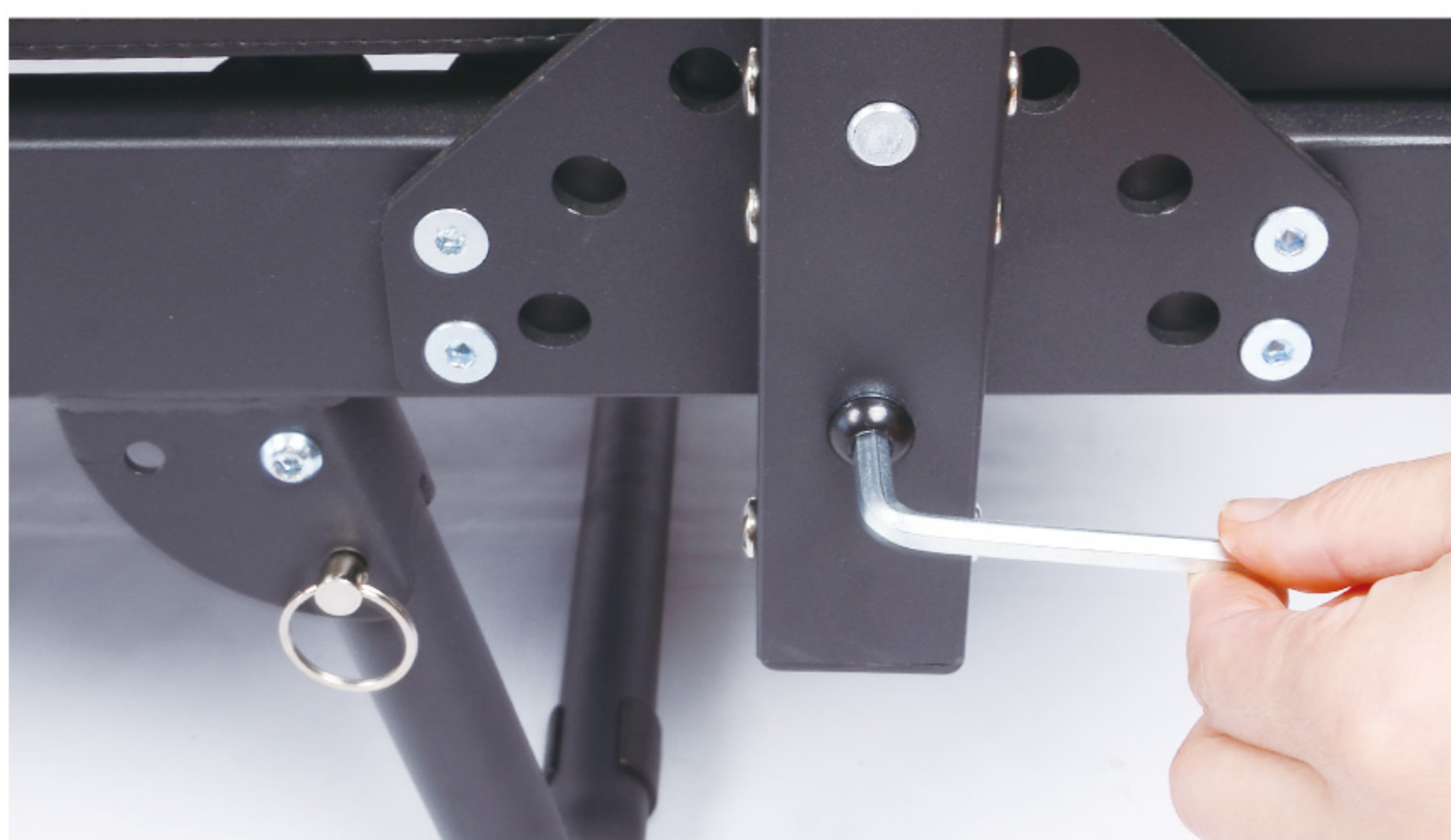

23. Take the M10\*40 bolt and insert it into the bottom hole of the armrest plate. Install a washer on the other side and tighten it with a large hex wrench.



24. Lift the foot pillow.

## Installation steps 04



25. As shown in the figure, remove the latex tube.



26. Push the cushion to the other side.



27. Take a stop block and M8\*30 bolt, insert them into the hole.



28. Use a small hex wrench to tighten the bolt.



29. Use a small hex wrench to tighten the bolt.



30. As shown in the figure, install the other side stop block.



31. Snap the spring onto the hook.



32. The number of latex tubes can be adjusted, and the tension can be controlled during use.

## Installation steps 05

---



33. Put back the foot pillow.



34. Insert the foot pillar into the hole and tighten it.



35. Insert the foot pillar into the hole on the other side and tighten it.



36. Take the wheel and M8\*16 bolt/gasket, and tighten them with a small hex wrench.



37. Follow the steps in Figure 36 to install the wheel on the other side.



38. Install two shoulder pad as shown in the picture.



39. Place the foot mat at the bottom of the tripod and complete the installation.

## Step of folding 01

---

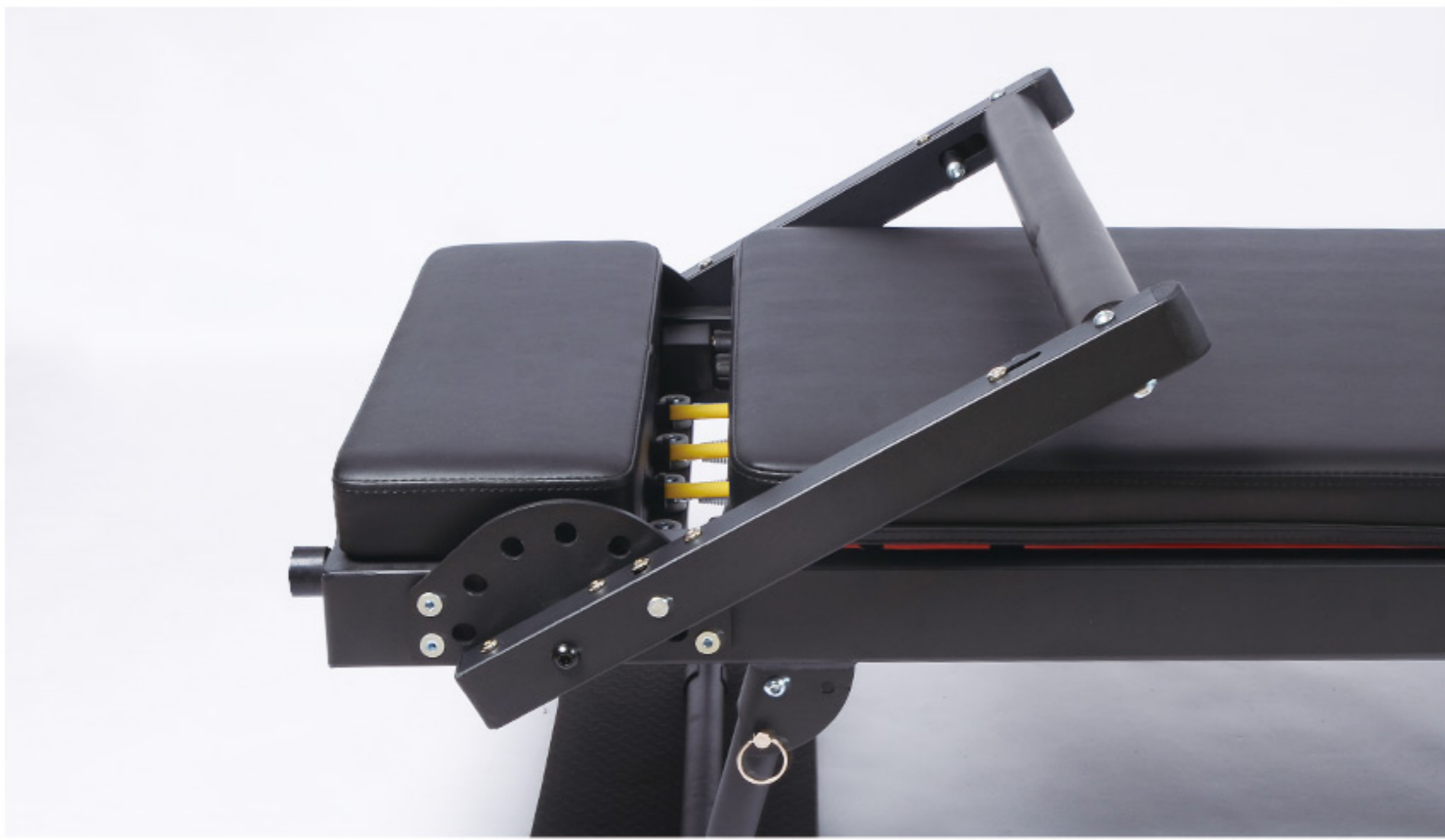

1. Adjust the armrest tube to the position shown in the picture.



2. Pull out the support pins on both sides of the front stand.



3. Pull out the support pins on both sides of the rear tripod.



4. Lift the frame, fold the tripod, insert the support pin to lock it.



5. Fold the front tripod and insert the support pin to lock it.

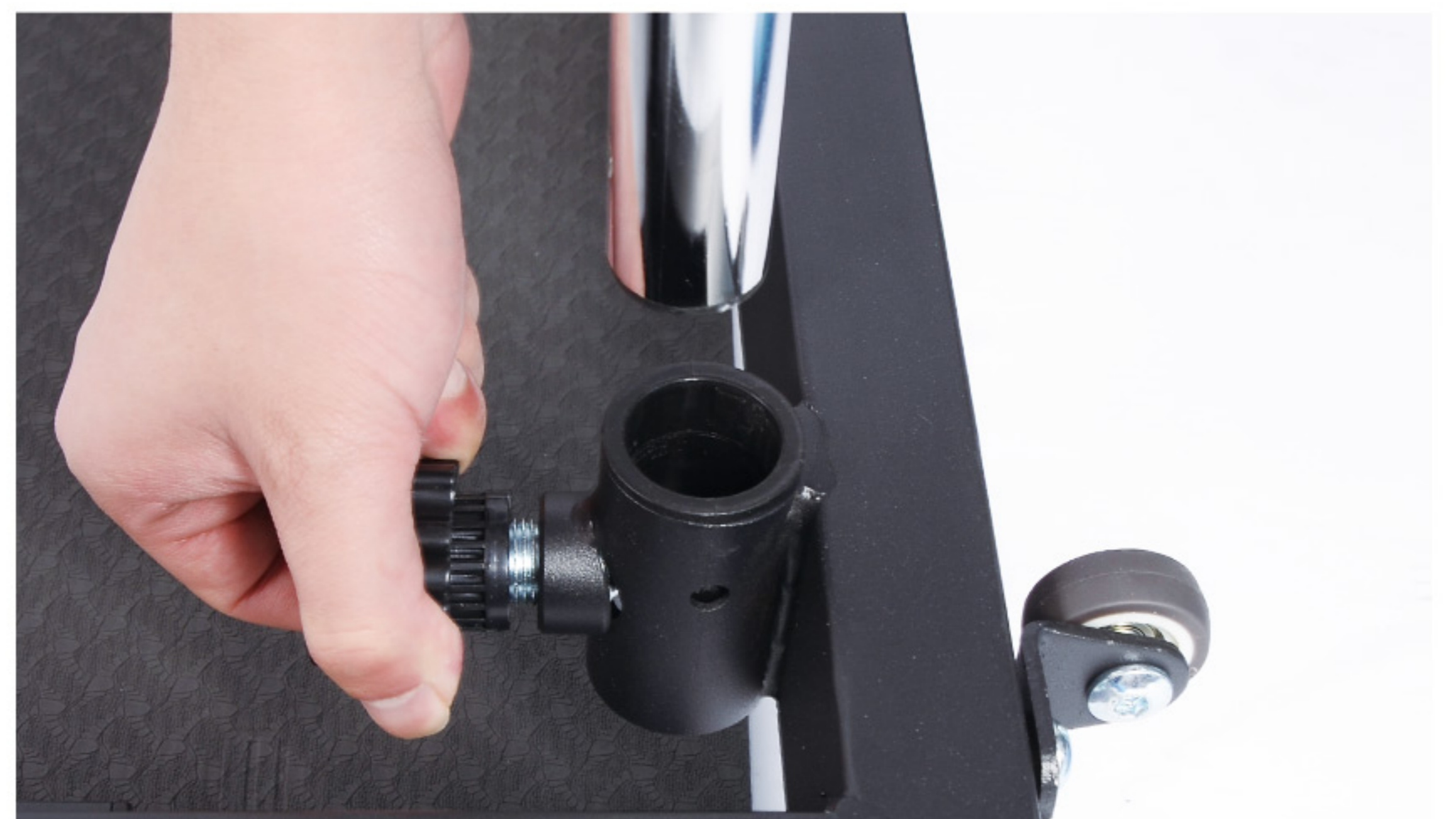

6. Pull out the adjustable knob and take out the pulley rods on both sides.



7. Pull out the folding pins connecting the two sides in the middle of the frame.



8. Grasp the folding armrest below the panel and lift it upwards.

## Step of folding 02

---



9. Insert two support pins into the side holes on both sides to lock the steel frame.



10. Place the pulley rod and shoulder into the storage hole.



11. Folding completed.

## NOTE WHEN USING AGAIN



1. Take out the two pulley rods and the shoulder pads.



2. Pull out the two side latches and unfold the frame.

# Concentrated upper limb exercise



**Spine stretching**

Kneel on your knees, stretch your upper limbs forward, grab the pole with your arms to stretch your spine.



**Mermaid**

Take a mermaid pose, one arm is placed on the fixed handrail rod, and the other arm is in a long live pose to stretch the ribs.



**Side twist**

Take a mermaid pose, rotate your body to the fixed foot, and push your arms forward.



**Exercise abdominal and arm muscles**

Grasp the drawstring and stretch your arms backwards while exerting force on your abdomen.



**Improving the spine ,waist exercise**

Grasp the drawstring and rotate your body with the roller down.



**Relieve discomfort in the back and shoulders**

Grasp the drawstring and open your chest with your arms bent.

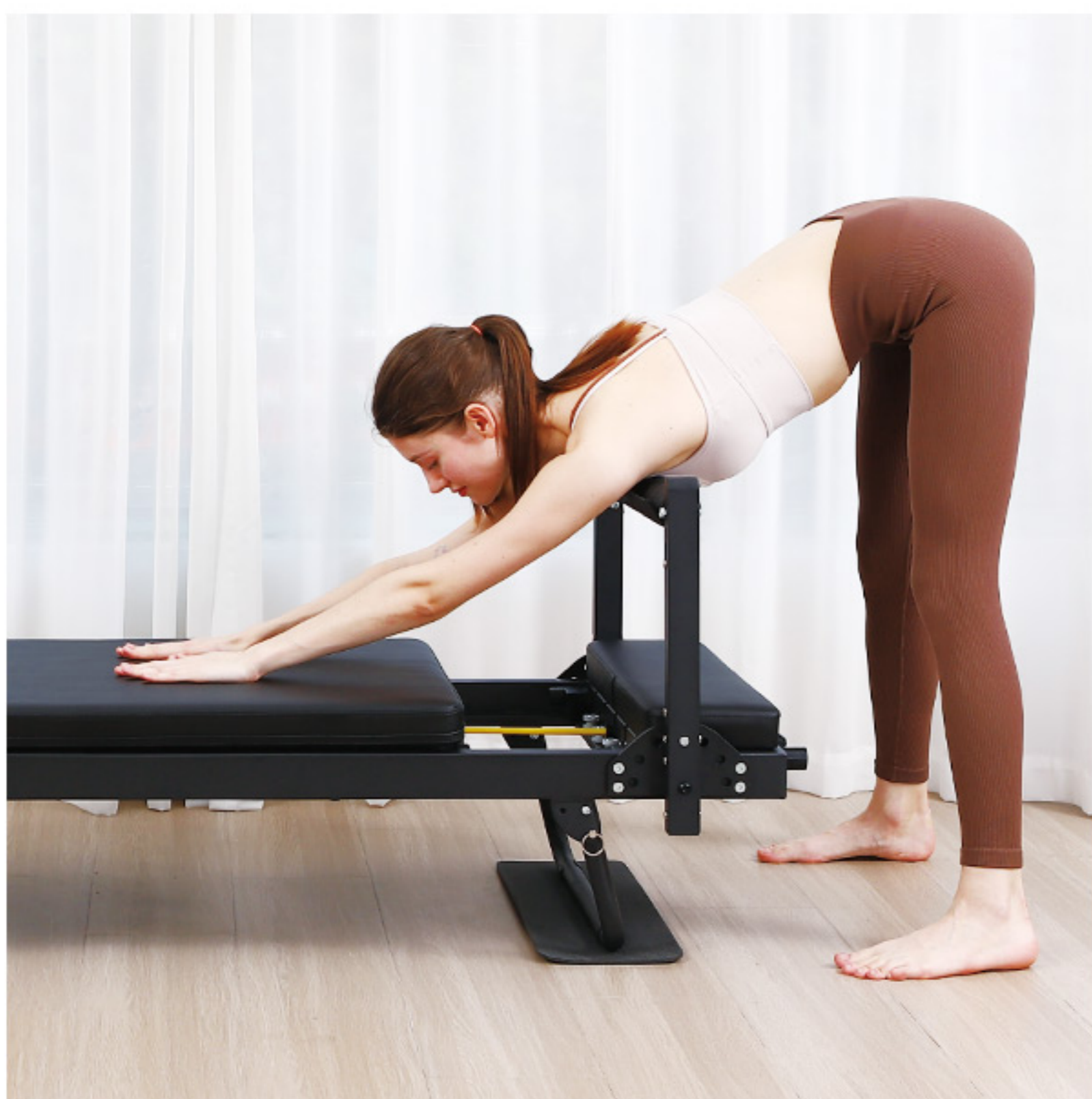

**Spine stretching**

Pushing the cushion forward while standing upright can help the spine stretch.



**Shoulder exercise**

With both knees on the cushion, one arm grasps the drawstring to open the shoulder joints.

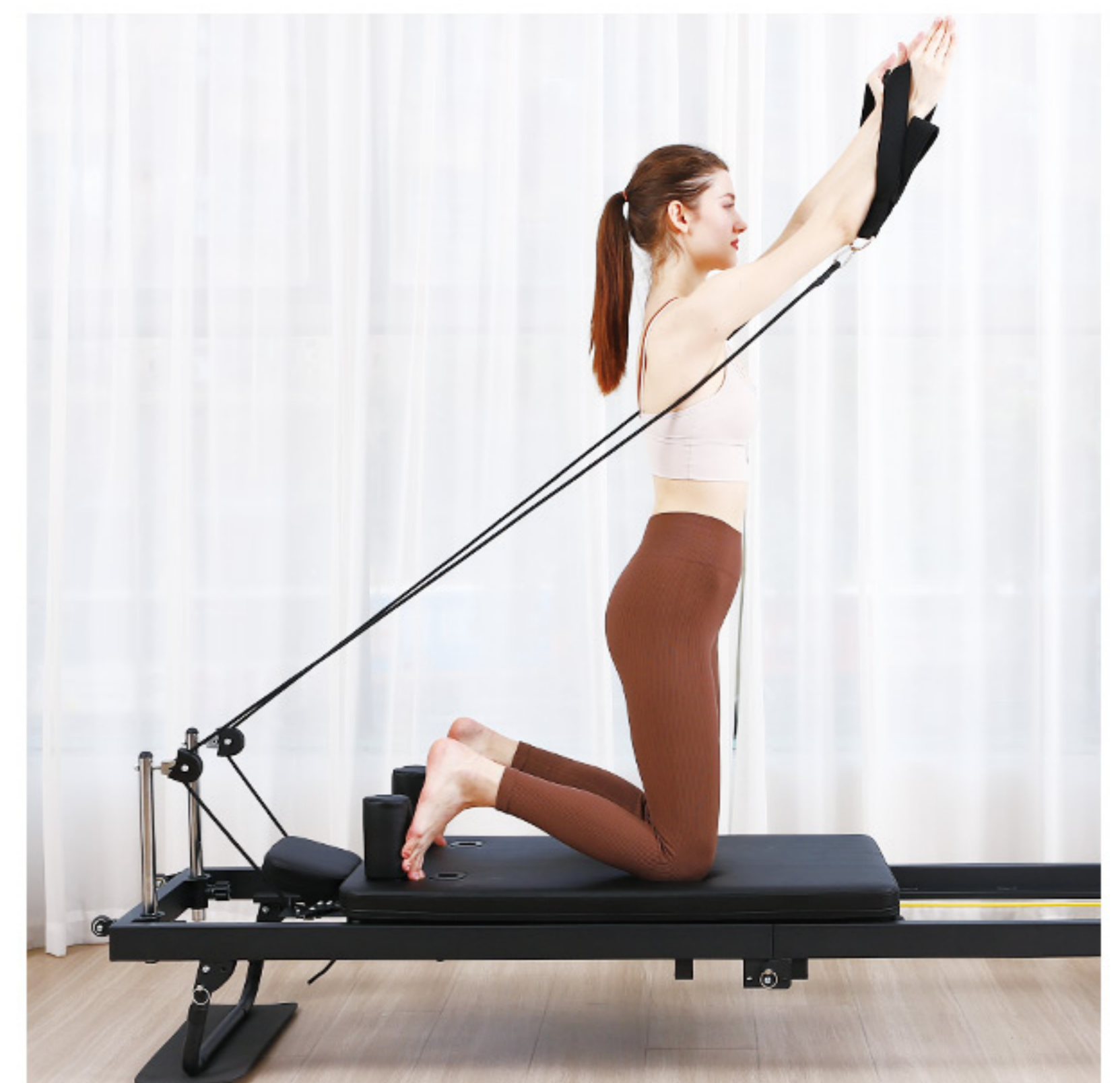

**Shoulder flexion**

With both knees on the cushion, control the center and push and pull your arms forward.

# Concentrated lower limbs exercise 1



## Buttock's stretching

Place one foot in a cross-legged position behind the handrail rod, while pushing and pulling the cushion, while stretching the hip muscles.



## Hip extension reverse

Put your hands on the shoulder pad, one foot on the handrail rod, and use the hip muscles to push and pull.



## Psoas stretching Relieve back pain

Place one foot on the cushion and extend it backwards. At this time, put your strength behind the supporting leg to keep your upper body upright.



## Exercise the muscles of the buttocks and legs

Be careful not to lower your waist excessively and lift one leg up hard on your hips.



## Hip knee movement

Don't shake your body, lift your knees toward your abdomen and then extend back.



## Psoas stretching Relieve back pain

Place one foot in front of the handrail rod and place both hands on the handrail rod. Be careful not to lower the waist excessively and stretch the front muscles of the pelvis.



## Hip extension with strap

Put your hands on the shoulder pad, hang a drawstring on one foot, and use the hip muscles to stretch.



## Improving pelvic bones ,leg muscles

Kneel on the cushion with one knee, place the other foot on the handrail rod, grasp the center of gravity and open the knee.



## Hip extension reverse

Put your hands on the shoulder pads and use your hip muscles to lift your feet.

# Concentrated lower limbs exercise 2



**Hamstring stretching1** Improvement of back

Try to stretch your upper limbs and stretch the back muscles of your thighs.

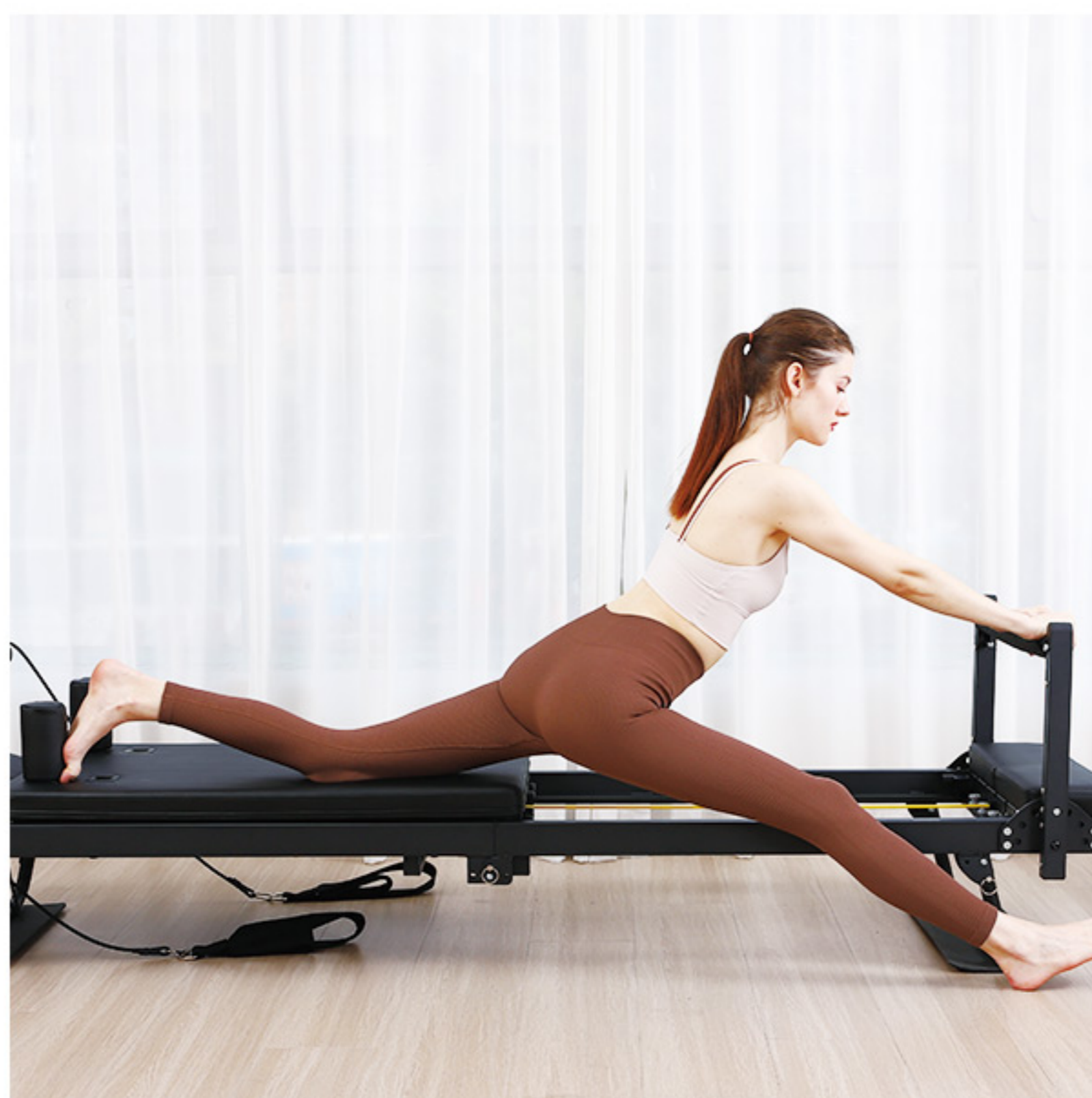

**Hamstring stretching2** Improvement of back

Put one foot on the cushion and stretch back and stretch the supporting leg forward.



**Strengthen muscles** Buttocks and inner thighs

After removing all the springs, stand in middle of the cushion, stretch one foot back, and open your arms to both sides.



**lunge reverse** Muscle strengthening

Standing on the cushion, long live to the shoulder lever.



**Adductor exercise2** Train inner thigh

With one foot on the ground and one on the cushion, train the inner thigh muscles without springs.



**Strengthen muscles**

Stand on top of the cushion, grasp the center of gravity and train.



**Adductor stretching** Train inner thigh

Put one foot on the shoulder pad and one foot on the ground. Exercising stretch the inner thigh muscles.



**Side lying** Improve leg lines

After lying on your side, hang a stretch band on one foot and raise your leg up and down while maintaining the curve of your spine.



**Frog exercise** Pelvic improvement

Hang the stretch straps behind your feet and bend your knees, open your knees until your feet form a V shape.